



# **Axon Dock User Guide**

Body 2 and earlier

Rev: 09 Apr 2025

Axon Enterprise, Inc.  
17800 N 85th St  
Scottsdale AZ 85255  
USA

▲, ▲ AXON, Axon Dock, Axon Evidence, and Axon Fleet are trademarks of Axon Enterprise, Inc., some of which are registered in the US and other countries. For more information, visit [www.axon.com/legal](http://www.axon.com/legal). All other trademarks are property of their respective owners.

All rights reserved. ©2025 Axon Enterprise, Inc..

# Contents

<b>Introduction</b> .....	<b>1</b>
Health and safety warnings .....	1
Axon Dock types .....	1
Additional materials .....	3
Find dock information in Axon Evidence .....	3
Registration .....	4
<b>Network configuration</b> .....	<b>6</b>
Network requirements .....	6
Firewall configuration .....	6
IP address configuration .....	7
<b>Installation</b> .....	<b>8</b>
Registration video .....	8
Step 1: Accept the Axon Evidence administrator invitation .....	8
Step 2: Assemble the dock .....	8
Step 3: Connect to network .....	10
Step 4: Connect to the dock .....	11
Step 5: Device configuration .....	11
Step 6: Administrator login .....	12
Step 7: Registration .....	12
Step 8: Confirm registration .....	14
Battery charging and LEDs .....	14
<b>Attach the desk plate</b> .....	<b>15</b>
Tools and materials .....	15
Preparation .....	15
<b>Change dock interface to HTTPS</b> .....	<b>17</b>
<b>Wall-mount, multi-bay</b> .....	<b>19</b>
Safety instructions .....	19
Tools and materials .....	19
Dimensions .....	19
Step 1 – Preparation .....	21
Step 2 – Attach the dock to the wall mount bracket .....	21
Step 3 – Identify dock placement .....	21
Step 4 – Attach the wall mount bracket to the wall (stud mount) .....	22
Step 5 – Attach the wall-mount bracket to the wall (drywall mount) .....	22
Step 6 – Connect the cables .....	23

<b>Troubleshooting</b> .....	<b>24</b>
Axon Dock FAQs and errors .....	24
<b>Technical information</b> .....	<b>30</b>
Technical support .....	30
Warranty .....	30
Compliance marks .....	30

## Introduction

Axon docks give Axon body cameras a wired network connection to Axon Evidence or Evidence Local to upload evidence and download camera updates. While information transfers securely to your organization's account, the dock also recharges the camera's battery.

As of firmware v3.20 (late 2024), Axon Dock supports IPv6, IPv4, and IPv6/IPv4 dual-stack environments, plus support for multiple languages.

## Health and safety warnings

Read the latest warnings and instructions Save this manual.

The health and safety warnings are to reduce the risk of personal injury or property damage. **Read those warnings fully before using this product.**

## Axon Dock types

Axon has different docks for Axon Body, Body 2, Fleet, and Flex.

Axon's dock has two major parts. One is the core module, which connects to the internet and transfers information to Axon Evidence services. The other is the individual bay, which accepts the Axon hardware. The system is modular, and up to five individual bays can be connected to one core.

The type of bay you use depends on which Axon camera you use. There are three individual bay designs for:

- Axon Body cameras and Axon Flex cameras and controllers
- Axon Body 2 and Axon Fleet cameras
- Axon Flex 2 cameras and controllers

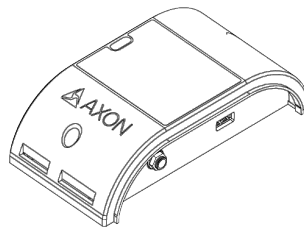

Core

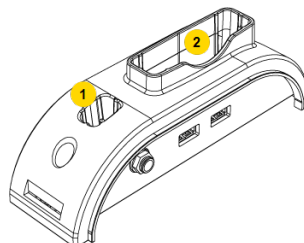

Individual bay for Axon Body Cameras and Axon Flex systems

1. Axon Flex camera port
2. Axon Body camera or an Axon Flex controller port

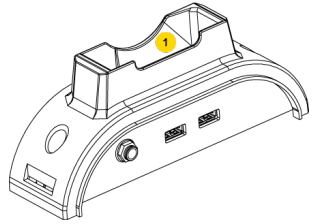

**Individual Bay for Axon Body 2  
Cameras**

1. Axon Body 2 camera or an Axon Fleet camera port

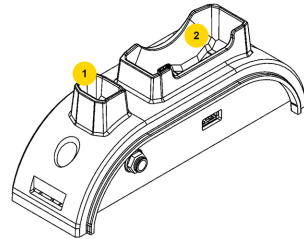

**Individual Bay for Axon Flex 2  
Systems**

1. Accepts an Axon Flex 2 camera
2. Accepts an Axon Flex 2 controller

A 6-bay dock is also available. As with the individual bays, there are three different models. One accepts Axon Body cameras and Axon Flex cameras and controllers (below left). Another accepts Axon Body 2 and Axon Fleet cameras (below right). The third is designed for Axon Flex 2 cameras and controllers (not shown below).

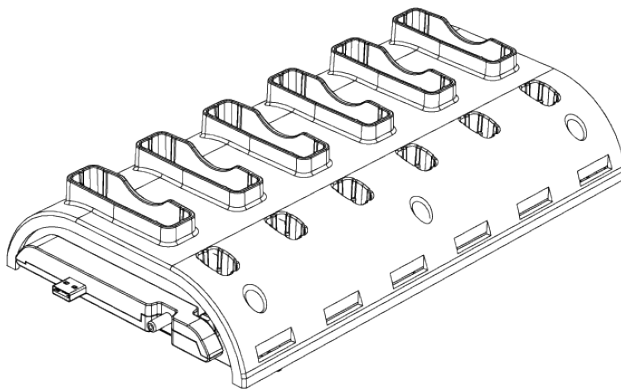

**6-bay for Axon Body Cameras and Axon Flex systems**

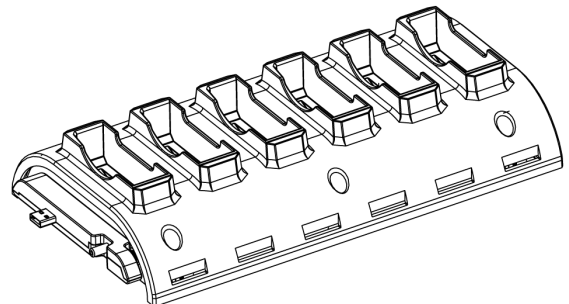

**6-bay for Axon Body 2 and Axon Fleet Cameras**

Use a bridge adapter to attach the core to a bay and to attach individual bays to each other.

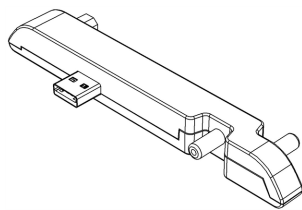

**Bridge adapter front**

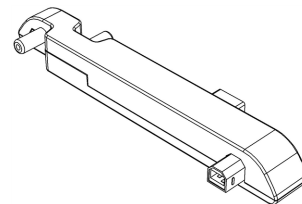

**Bridge adapter back**

Be careful when removing a bridge adapter from a bay, as damage may occur if the bridge adapter is removed unevenly from the bay. Bridge adapters must be pulled straight out and not angled when removed.

Use a locking adapter to fasten a core and bays together.

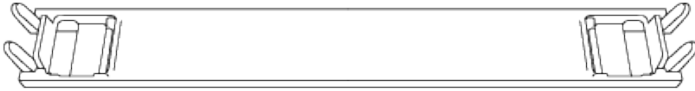

## Additional materials

---

An Axon Dock may come with an ethernet cable and an external power supply.

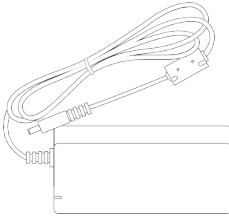

Power supply, 8-Bay Dock  
(SKU 100142)

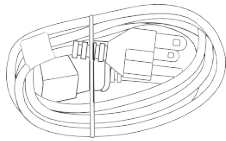

Power supply, 1-Bay Dock  
(SKU 71104)

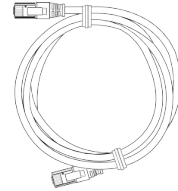
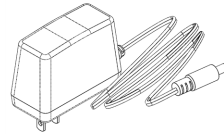

Ethernet  
cable

## Find dock information in Axon Evidence

---

Information about an Axon Dock and the devices connected to them is available in your agency's Axon Evidence account by going to the **Device Profile** page for the dock. Your dock must be registered (see next section) to use this page.

The Device Profile page shows the dock model, serial number, and status of cameras connected to the dock. The **Connected Devices** section of the page is built by assembling the reports sent from a camera each time it is docked.

This screen shows an Axon Legacy Dock single-bay device profile page in Axon Evidence.

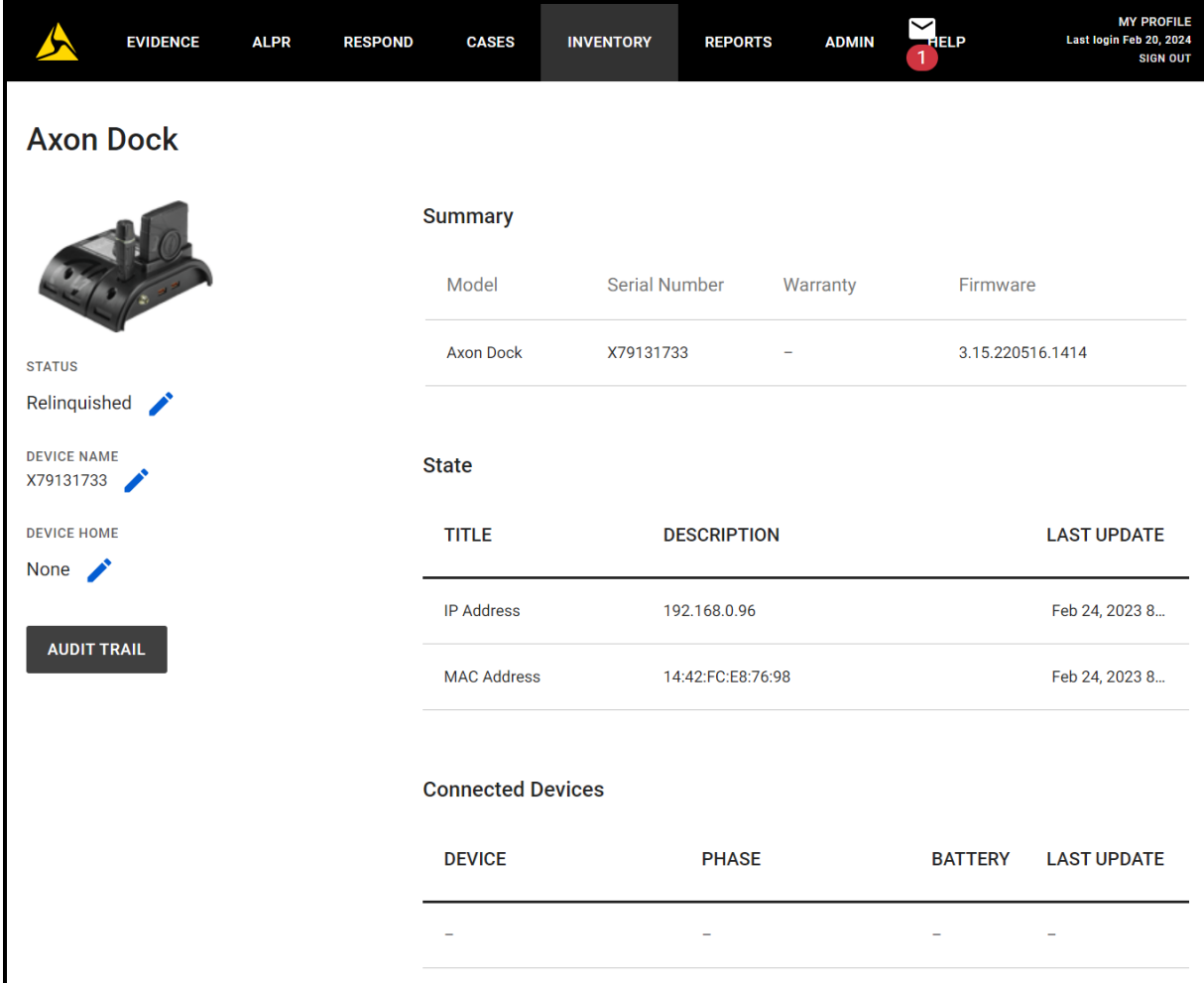

**Axon Dock**

**Summary**

Model	Serial Number	Warranty	Firmware
Axon Dock	X79131733	-	3.15.220516.1414

**State**

TITLE	DESCRIPTION	LAST UPDATE
IP Address	192.168.0.96	Feb 24, 2023 8...
MAC Address	14:42:FC:E8:76:98	Feb 24, 2023 8...

**Connected Devices**

DEVICE	PHASE	BATTERY	LAST UPDATE
-	-	-	-

**Metadata:**

- STATUS: Relinquished
- DEVICE NAME: X79131733
- DEVICE HOME: None

**AUDIT TRAIL**

## Registration

If you do not have an Axon Evidence account, contact your Axon administrator and ask for an account invitation. When the email invitation arrives from [noreply@evidence.com](mailto:noreply@evidence.com), accept it and create an account.

Registration and configuration of Axon Docks is not required, but registering does make inventory management of your docks, including returns through Axon Evidence, much easier. Your dock must be registered to use the Device Profile page in Axon Evidence.

1. Use Axon Device Manager (ADM) to register and name Axon Body Docks for inventory and management purposes.
2. When using the ADM Tap Device option to look for the NFC tag (for Body 3, Workforce, and Body 4), hold your mobile device near the  icon on the dock. For the 1-bay dock, the icon is on the side of the dock nearest to the ethernet port. For the 8-bay dock, the icon is near bay 1, on the side of the dock near the power connection.

3. Use logical names when changing the Device Name in Axon Evidence. This will assist in understanding the location and purpose for the dock.
4. Use the [Device Home](#) feature in Axon Evidence if you have more than one location with Axon Docks.

## Network configuration

Axon Body Cameras capture video and audio recordings. Place the camera in an Axon Dock to securely upload the content securely to your agency's Axon Evidence or Evidence Local instance.

An Axon Body Camera can be docked in any compatible Axon Dock and still connect to your evidence repository to upload video. When docked, the camera obtains its own IP address to establish a direct encrypted communication channel. The dock functions as an ethernet adapter, unmanaged network switch, and charger.

To get a dock up and running, you may need some assistance from your IT department.

If you have questions, contact Axon customer service.

### Warning

Never connect a dock directly to the internet. The dock must be connected behind a firewall or secure network.

## Network requirements

To get the dock up and running, you may need some assistance from your IT department.

An Axon dock generates Internet Control Message Protocol (ICMP) packets to the DNS and gateway every 3–7 minutes to update the status of the gateway/DNS on the status page. Your network must allow for the transmission of these packets.

Although the dock is hardened against external intrusion, follow industry standard security policies and place the dock behind your agency's firewall or secure network for maximum security. **Do not** connect the dock directly to the internet.

## Firewall configuration

The dock and Axon devices do not require any incoming data ports for regular operation. All video and data files transmit securely using HTTPS (SSL) and 256-bit AES encryption. For proper operation, the dock requires the following outbound firewall ports:

1. Port 443 (TCP) opened for outgoing traffic to your agency's Axon Evidence instance (youragency.evidence.com). This is used to send video and data files to Axon Evidence or Evidence Local using the HTTPS protocol.
2. Port 53 (UDP) opened for access to DNS, if your network uses external (internet) DNS servers. When using external DNS servers this is necessary for the dock to locate the servers for your Axon Evidence account.
3. Port 80 (TCP) for time synchronization.

Accessing the dock interface through HTTP:80 will always redirect to HTTPS:443 for a secure connection.

If the **Accept only SSL Requests** option on the Admin page of the interface is unchecked, you can access Dock UI using HTTP:8080. If checked, you won't be able to access Dock UI via HTTP:8080.

Once registered to your agency, the dock uses one of two methods to synchronize clocks on Axon devices:

1. HTTP over port 80 (TCP) to synchronize time from youragency.evidence.com
2. HTTPS over port 443 (TCP) to synchronize time from youragency.evidence.com

The dock requires only one of the above methods to be available. By default the dock uses Method 1 and requires port 80 be enabled for outbound access on the firewall. Method 2 is the most secure, requiring no additional ports to be opened in a firewall. However, in certain rare circumstances the HTTPS connection can fail if the clock on the dock is too far out of sync with the actual time. To enable Method 2, select the **Require SSL For Initial Time Check** checkbox on the dock Admin page.

Before being registered to your agency, the dock will perform time synchronization against "time.evidence.com."

The Axon system does not currently support HTTP/HTTPS proxies. If you put the dock on a network where a proxy is used to access web sites, the IP assigned to the dock must be allowlisted. Depending on the specific network setup, this may require a static or reserved DHCP IP. We recommend using a DHCP reservation whenever possible to minimize configuration overhead.

**Note** Axon systems no longer support Microsoft Internet Explorer.

## IP address configuration

---

By default the dock uses standard DHCP to obtain an IP address from your agency network. If your agency uses the 10.10.1.x IP address range for your internal department network this may conflict with the default IP address used by the configuration port (10.10.1.1). In this case it is necessary to set the dock's configuration network address before connecting the dock to your network the first time.

## Installation

These steps for dock installation and registration apply to both a TASER Weapons Dock and Body 2 and earlier docks.

If your dock is not registered to your Axon Evidence account, device logs will not upload. To register, you need the dock, a computer, power, and two ethernet cables.

Before registering:

- Accept the Axon Evidence administrator invitation email. If you don't, you won't be able to register the dock.
- Know your user name, password, and agency domain name.
- Ensure either:
  - a. You are assigned to an Axon Evidence **Admin** role, or
  - b. Your assigned role has the **Register TASER, Body 2, and Flex 2 Docks** permission set to **Allowed** (found in **Admin > Agency Settings** section > **Roles & Permissions > your role**).

### Registration video

---

To register a TASER Weapons dock, skip to [Step 3: Connect to network](#) on page 10.

### Step 1: Accept the Axon Evidence administrator invitation

---

Ensure you know your user name, password, and agency domain name. This email invitation will come from [noreply@evidence.com](mailto:noreply@evidence.com).

If you do not accept the invitation, you will not be able to complete dock setup.

### Step 2: Assemble the dock

---

1. Take the dock out of the box and connect your core to all bays you plan to use. Do not attach more than five individual bays or one 6-bay to one core.
2. Press the components together firmly so they fit flush, matching the ports as shown (1-to-1, 2-to-2). You should hear a click when pushing the core, bays, and bridge adapters together.

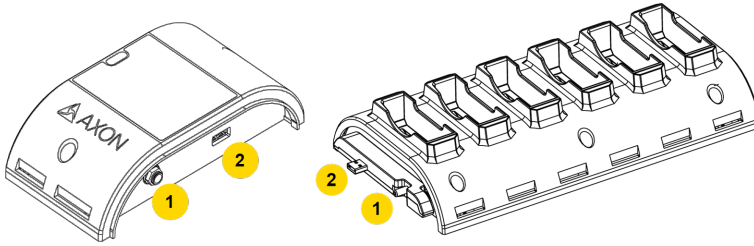
**CAUTION**

Potential data and power loss. The system will not provide power to more than five individual bays on one core. Axon cameras in any extra bays will neither charge nor upload data to Axon Evidence.

3. Turn the dock upside down.
4. Press the locking adapter into place between the core and bay. The two prongs on each end of the locking adapter should snap into place to hold the core and bay together.

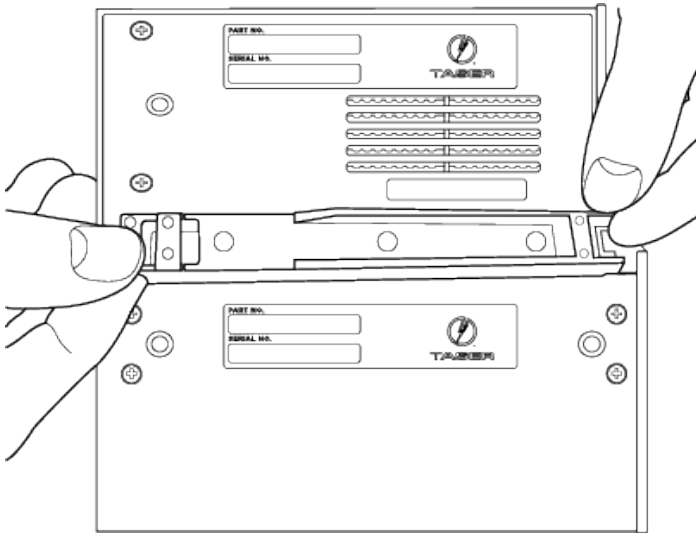

- When properly installed, the locking adapter is flush in place with the core and bay.

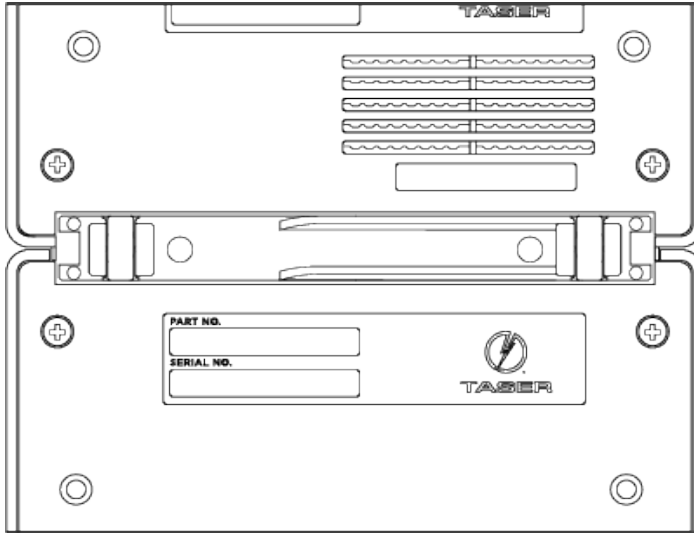

- Turn the connected dock right side up and place on a flat surface within reach of power and ethernet connections but away from heat sources and direct sunlight. For wall-mounting, see [Wall-mounting, multi-bay](#) on page 19.

### Step 3: Connect to network

The back of the dock core has two ports for ethernet cables: WAN and MGMT (LAN). The USB port on the rear of the core is non-functional.

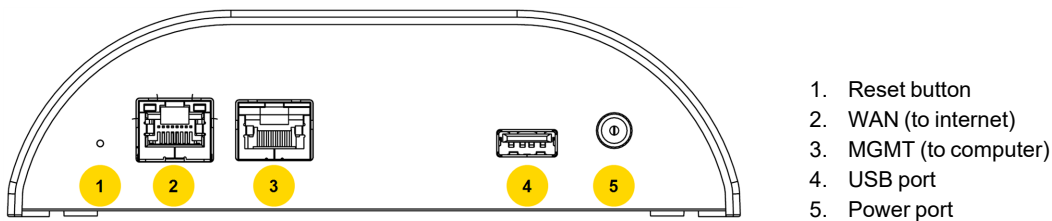

- Plug one ethernet cable into the WAN port, and its other end into a networked agency port.
- Plug the other ethernet cable into the MGMT (LAN) port, and its other end into your computer.

**CAUTION** DO NOT connect the MGMT (LAN) port to the networked agency port.

- Connect the power cord to the power supply.
- Connect the power supply plug to the core and plug the adapter in a power outlet. The green **Power** LED on top will illuminate when the dock is powered.
- Allow the dock five minutes to fully start. The green **Status** LED on top will light up when the dock has started.

## Step 4: Connect to the dock

---

1. On the computer connected to the dock:
  - a. Ensure the computer has internet access for signing into Axon Evidence.
  - b. Disable any VPN (remote access) software.
2. Open a web browser (Internet Explorer is no longer supported).
3. In the URL address box, enter 10.10.1.1 and press **Enter**.
4. In the **Configuration Assistant** dialog box, select **OK**.

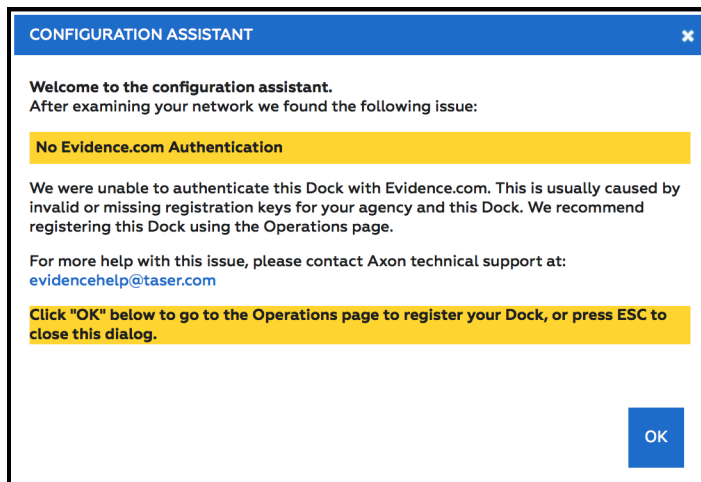

## Step 5: Device configuration

---

Complete the information for the **Authentication Required** dialog box.

1. For **User Name**, enter *admin*.
2. For **Password** box, enter *admin*.
3. Select **OK**.
4. Set a new password:
  - a. In the Administration tab, enter the existing user name and password.
  - b. In the **Password Change** section, enter a new password twice.
  - c. Select **Save Changes**.

### CAUTION

Potential system access loss. Ensure you remember the password. It can't be reset.

## Step 6: Administrator login

1. Enter your agency's Axon Evidence **Domain name**. For example, in `axon.evidence.com`, `axon` is the domain name.

The screenshot shows the Axon Dock Administration interface. The top navigation bar includes: AXON Dock, STATUS, NETWORKING, OPERATIONS, ADMINISTRATION, and FIRMWARE. The current page is titled "OPERATIONS" and shows "FIRMWARE VIETNAM - THHUYNH-DOCK-TEST" for "SCOTTSDALE, AZ" with a timestamp of "11/25/2021 - 14:56:22". The main heading is "EVIDENCE.COM REGISTRATION". Below this, there is a text instruction: "To register this Dock to your Evidence.com Agency enter your Evidence.com agency name. Once the Dock is registered to Evidence.com, it will transfer all media files to your Evidence.com account." There are two input fields: "Evidence.com Agency" and "Domain name". The "Domain name" field is currently empty. At the bottom of the form are two buttons: "RESET REGISTRATION" and "CONTINUE". The footer contains a dropdown menu, "© 2020 Axon Enterprise, Inc. All rights reserved", "support@axon.com", and "Help Center".

### Note

After 15 minutes of inactivity, the app will open a new tab and ask you to sign back in with your Axon Evidence credentials.

2. Select **Continue**.
3. Select the link in the "Please open..." sentence and use the number provided there to complete registration.

The screenshot shows the same Axon Dock Administration interface as the previous screenshot. The "Domain name" field now contains the text "fwn.qa.evidence.com". Below the input fields, there is a text instruction: "Please open [https://fwn.qa.evidence.com/...](https://fwn.qa.evidence.com/) and provide 123456789 to complete registration." The "CONTINUE" button is now disabled (greyed out). The rest of the page, including the navigation bar, header, and footer, remains the same.

## Step 7: Registration

The system reports it is **Registering the dock**, then **Generating security tokens**, and finally **Restarting the dock**.

1. Allow two minutes for the system to restart.
2. On successful registration, a banner displays “This Dock has already been registered with Evidence.com”. This is not an error. Continue with step 8.

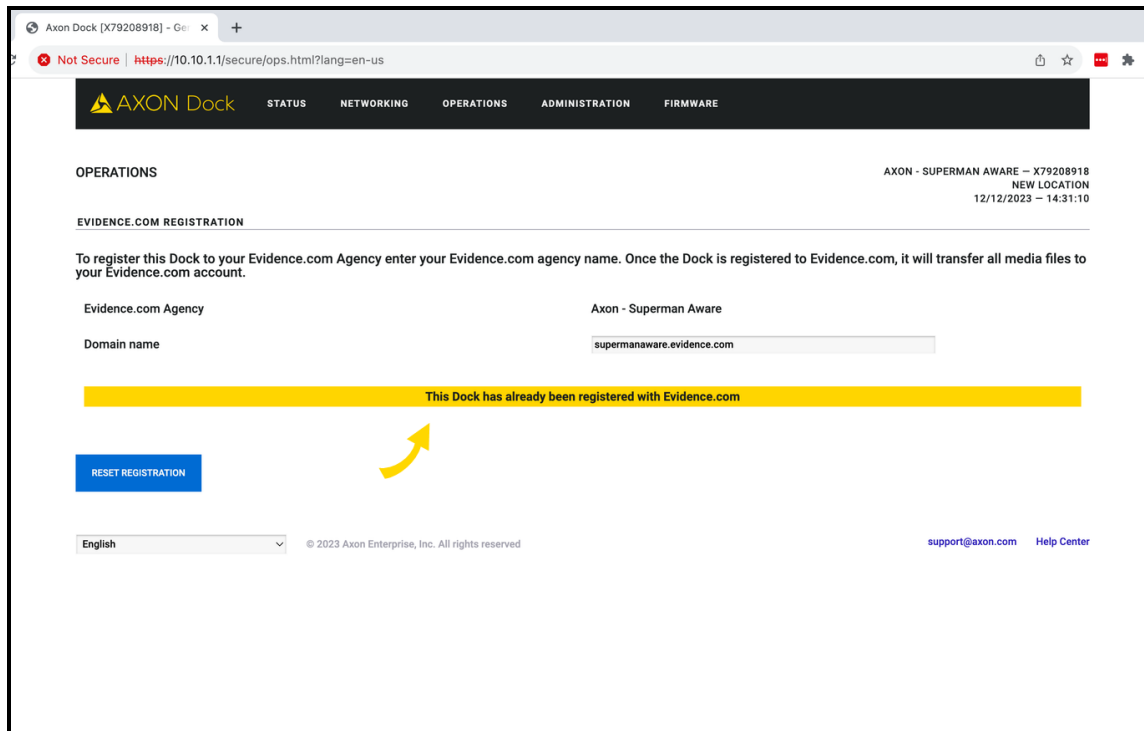

## Step 8: Confirm registration

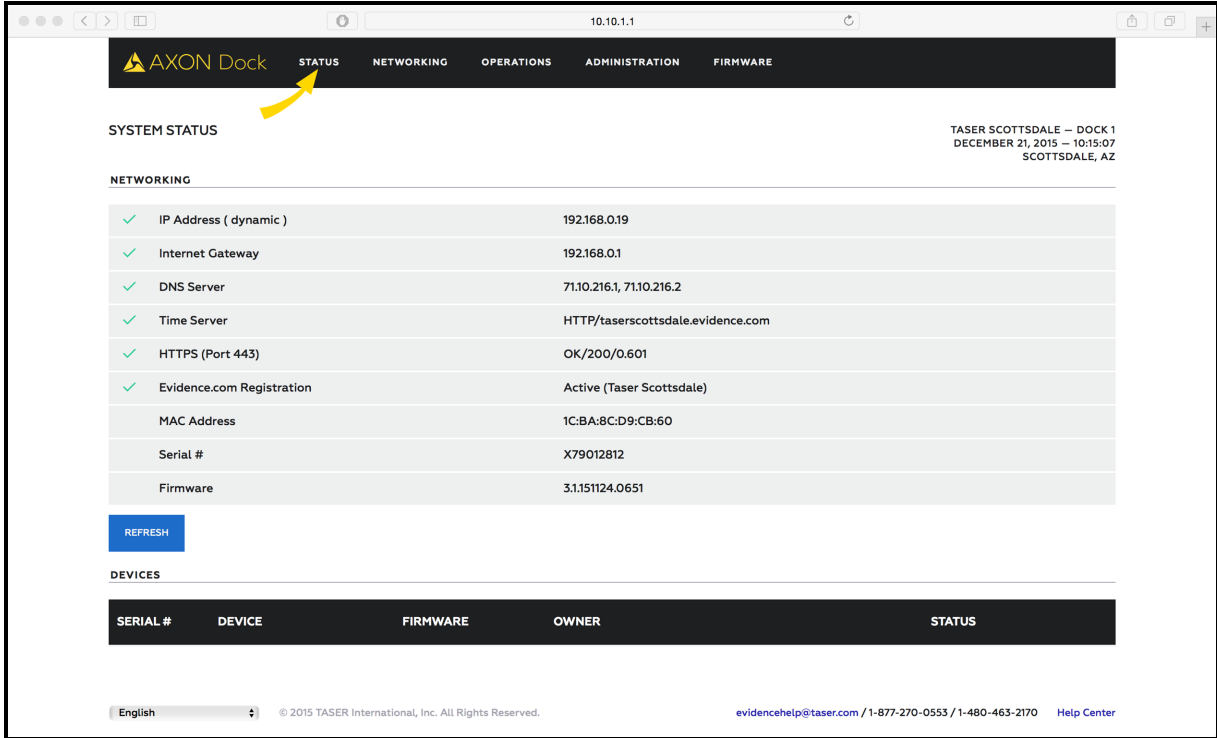

Select **Status** in the menu bar. There should be six green check marks on the left side of the screen. This dock is now registered.



## Battery charging and LEDs

An Axon Body 2 camera or Axon Flex 2 Controller will begin charging when placed in a bay. The color of the battery LED around the camera's EVENT button indicates the battery's status; see the camera's [user guide](#) for details on what the different LED colors and actions mean.

Axon Fleet cameras do not charge in the Axon Dock; the battery LED will display solid green.

Body Camera Battery Capacity	Battery LED while in Dock
Fully charged (greater than 98%)	 Green
Charging in progress (20–98%)	 Yellow
Charging in progress (less than 20%)	 Red

## Attach the desk plate

If you use your Axon Dock on a desk or table, you should attach your dock to a desk plate. The desk plate holds the core and bay together and keeps the dock from sliding on flat surfaces.

There are two desk plates. One is designed for use with a core and a single bay; the other is for use with a core and a 6-bay dock, which is what the pictures in this procedure show.

### Tools and materials

---

- Screwdriver
- Screws
- Desk plate
- Rubber feet

### Preparation

---

Read all of the manufacturer's installation instructions for the dock. Follow the instructions for putting the dock together in [Installation](#) on page 8.

1. Place the plate on a table with the flat surface facing up.

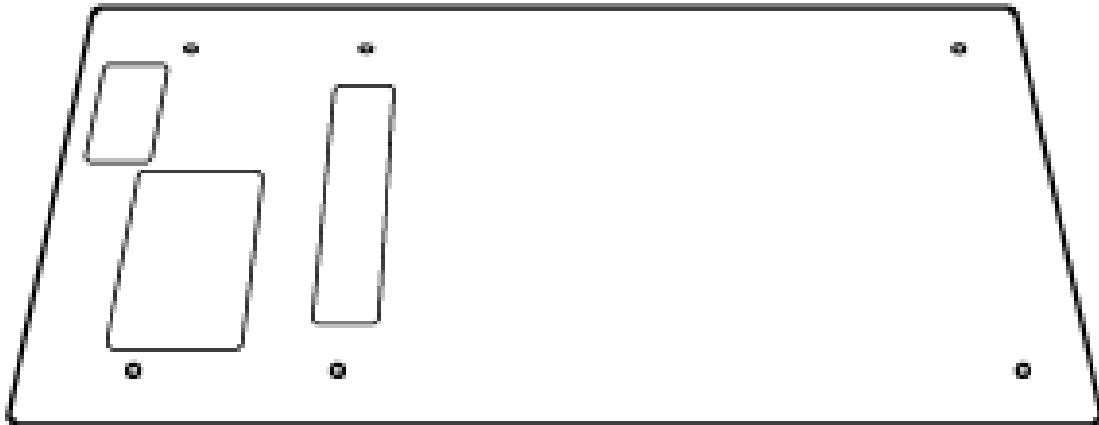

2. Place the core on the desk plate so the rectangular openings on the dock line up with the holes in the plate.

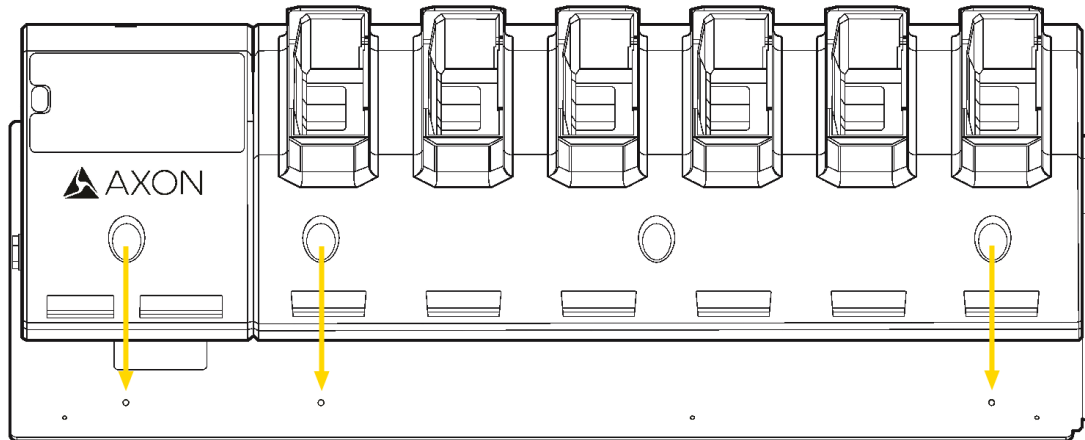

3. Drive the six screws into the dock.
4. Turn the dock and desk plate assembly over.
5. Remove the adhesive backing from the rubber feet and attach them to the round scored markings on the desk plate.

## Change dock interface to HTTPS

The Axon Dock administration interface for legacy docks uses HTTP by default when connecting with a browser (this connection is unrelated to the dock's HTTPS connection to Axon Evidence). For an added layer of security when connecting, you can enable HTTPS.

1. Connect a computer to your dock using the MGMT (LAN) port .
2. Enter 10.10.1.1 in the address bar of a browser and press Enter. If you have not signed in to the Axon Dock yet, enter the administrator **Username** and **Password** (different from your Axon Evidence credentials).

3. On the Axon Dock menu bar, select **Administration**.
4. In the **SSL Configuration** section, check the **Accept only SSL Requests** box and then select **Save Changes**.

5. Refresh the browser page. A browser warning notes "connection is not private".

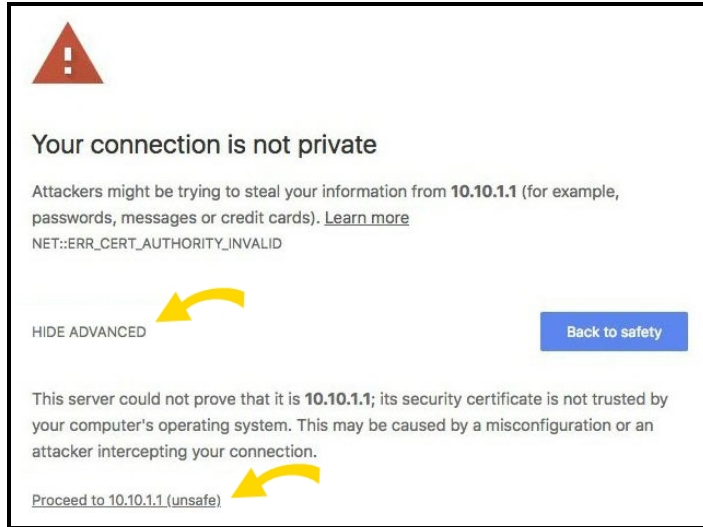

6. Select the option that lets you add the exception and install the dock security certificate. Each browser has a slightly different workflow; the above is from Google Chrome and requires you to select **Show Advanced** (which then becomes **Hide Advanced**) to show the lower part of the screen, then **Proceed to 10.10.1.1 (unsafe)**.

## Wall-mount, multi-bay

For desktop installation, see [Installation](#) on page 8.

Watch this [video](#) for an overview of dock mounting.

This section describes how to wall-mount a multi-bay dock. If you don't need to wall-mount your dock, skip to [Troubleshooting](#) on page 24.

### Safety instructions

---

Before mounting your dock:

- Ensure the area behind the wall where the dock will be located is clear of obstructions to avoid damage to surroundings, pipes, or existing wiring.
- Ensure your cables meet all applicable building and fire codes. For in-wall installation, most require UL-rated wire labeled CL2 or CL3.
- Leave adequate space around all sides of the dock for proper ventilation and maneuvering around it without people or items bumping it.

### Tools and materials

---

- Cable-wire tester/locator
- Level
- Pencil
- Drill and bits
- Screwdriver
- Stud finder
- Tape measure
- Wall-mount kit

### Dimensions

---

The dimensions below show the mounting hole locations of the wall mount bracket and the overall size of the assembly with the dock attached. Place the power supply behind the unit on the horizontal shelf.

### Dimensions for body cameras and Flex systems 6-bay dock

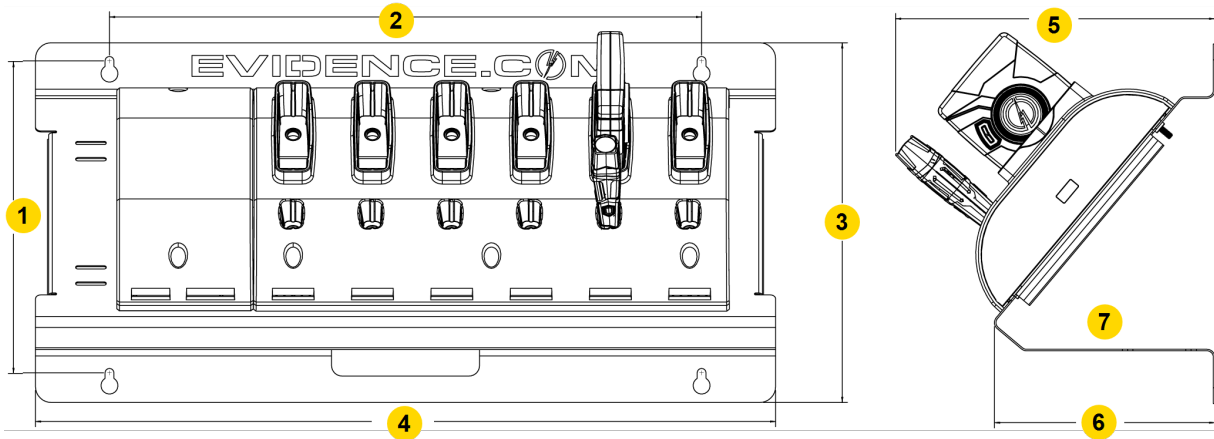

- |                                      |                            |
|--------------------------------------|----------------------------|
| 1. 7.375" (18.7 cm) center-to-center | 5. 7.55" 19.2 cm)          |
| 2. 14.0" (35.6 cm) center-to-center  | 6. 5.21" (13.2 cm)         |
| 3. 8.51" (21.6 cm)                   | 7. Place power supply here |
| 4. 17.5" (44.5 cm)                   |                            |

### Dimensions for Body 2 and Fleet camera 6-bay dock

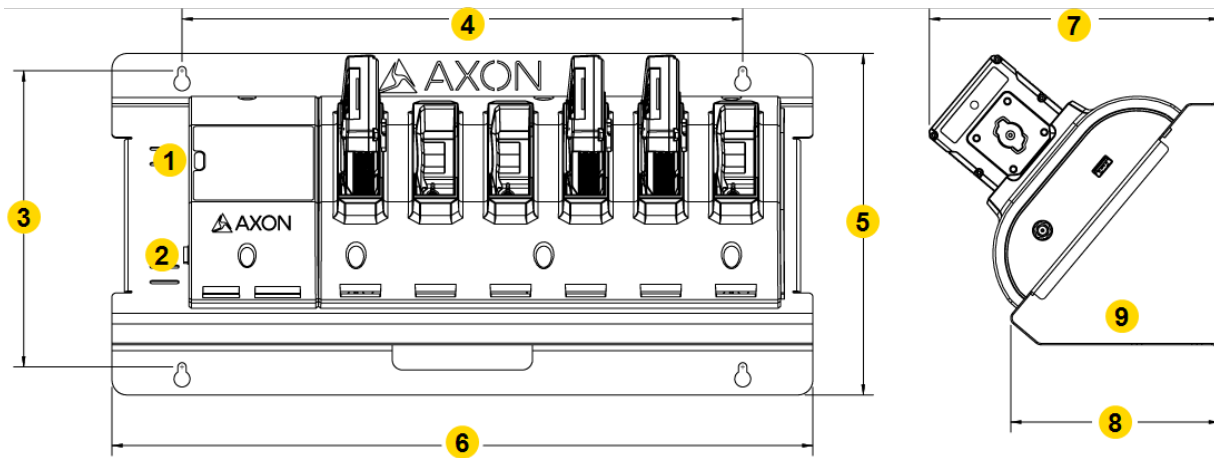

- |                                      |                            |
|--------------------------------------|----------------------------|
| 1. Ethernet port                     | 5. 8.51" (21.6 cm)         |
| 2. Power port                        | 6. 17.5" (44.5 cm)         |
| 3. 7.375" (18.7 cm) center-to-center | 7. 7.24" (18.4 cm)         |
| 4. 14.0" (35.6 cm) center-to-center  | 8. 5.21" (13.2 cm)         |
|                                      | 9. Place power supply here |

## Dimensions for Axon Flex 2 System 6-bay dock

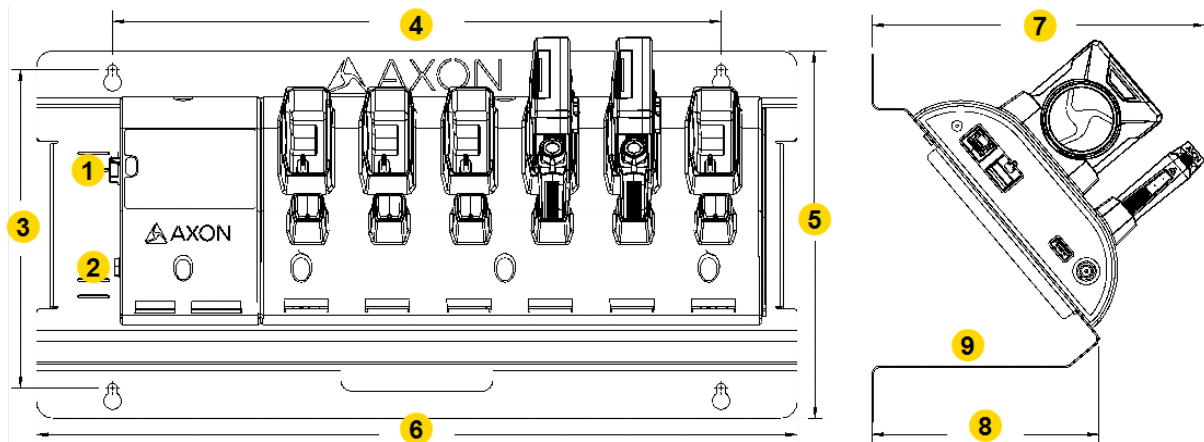

- |                                      |                            |
|--------------------------------------|----------------------------|
| 1. Ethernet port                     | 5. 8.51" (21.6 cm)         |
| 2. Power port                        | 6. 17.5" (44.5 cm)         |
| 3. 7.375" (18.7 cm) center-to-center | 7. 7.66" 19.5 cm)          |
| 4. 14.0" (35.6 cm) center-to-center  | 8. 5.21" (13.2 cm)         |
|                                      | 9. Place power supply here |

Use the overall size of the wall mount bracket to determine the spacing and fit between multiple assemblies.

### Step 1 – Preparation

1. Ensure you have all necessary hardware and cables required to complete the installation.
2. Read all installation instructions for both the dock and the wall mount bracket.
3. Decide if you will leave the cables showing or hide them in the wall behind your dock.

### Step 2 – Attach the dock to the wall mount bracket

1. Align the holes of the dock with the holes on the wall mount bracket.
2. Use the screws provided in the dock wall mount kit to attach the dock to the bracket.
3. As the screws come out the back of the bracket, attach the washers and add the wing nuts.
4. Tighten all screws.

### Step 3 – Identify dock placement

1. Find a location away from heat sources and direct sunlight that does not obstruct movement.

2. Choose a location close to an electrical outlet and a network outlet. Measure the length of the dock's power cord to ensure it will reach.

## Step 4 – Attach the wall mount bracket to the wall (stud mount)

---

Your wall mount kit comes with hardware for mounting the bracket to a stud or mounting directly into drywall (if mounting to drywall, skip to Step 5). Use the longer screw for mounting the bracket into a stud.

1. Using a stud finder, mark the location of each stud's center with a pencil.
2. Use a nail to confirm stud location.

### Note

Depending on the wall construction, you may not be able to mount both ends of the wall mount bracket into a stud. If needed, use the drywall anchors for the other mounting locations.

3. Position the wall mount bracket on the wall and align the mounting keyhole in the left side of the bracket with the center line of the stud.
4. Use a level to ensure the bracket is level before marking the holes.
5. Mark the center of the left side keyholes in the center of each wall stud.
6. Drill a pilot hole smaller than the screw diameter.
7. Install the screws into the stud until there is 1/8" (3.2 mm) of space between the bottom of the screw head and the wall. This will allow the bracket to be placed onto the screws and settle in the keyhole (the holes in the bracket are shaped like keyholes to make it easier to adjust the mount's position on the wall).
8. Repeat steps 4–7 for the other side of the mount bracket.
9. After the wall mount bracket is positioned correctly, tighten all of the screws.

Skip to Step 6.

## Step 5 – Attach the wall-mount bracket to the wall (drywall mount)

---

If installing the bracket to a wall stud, go to Step 4 above.

### Note

Use the screw-in anchors and shorter screws for drywall installations.

1. Locate the wall mount bracket on the wall.
2. Using a level to ensure the bracket is level, mark the center of the four keyholes.
3. Remove the wall mount bracket and install the drywall anchors.
4. Leave 1/8" (3.2 mm) of space between the bottom of the screw head and the wall to allow the bracket to settle in the keyhole.

## Step 6 – Connect the cables

---

There is space provided on the horizontal shelf to secure the power supply for the dock.

1. Position the power supply between the slots in the bracket and secure the power supply to the bracket with the Velcro strap.
2. Route the barrel connector around the edge guard and plug the barrel connector into the power jack on the dock.
3. Secure the cable in position with the attached zip tie and the associated slots in the bracket.
4. Plug the power supply cable into a power strip or nearby AC outlet.
5. Plug the CAT 5e (or better) cable from your agency's network data jack into the WAN port on the dock. Secure the cable in position with the attached zip tie and the associated slots in the bracket.

The power LED on top will illuminate green when the dock is powered.

## Troubleshooting

An Axon Dock provides a wired network connection for various cameras. It functions as an ethernet adapter, unmanaged network switch, and charger. As long as the dock has power and a network connection, it should continue functioning correctly.

### Axon Dock FAQs and errors

---

#### Time server shows 000 and/or a red X

---

1. In Axon Dock, select **Administration**, then **SSL Configuration**.
2. Check the boxes for both **Require SSL for Initial Time Check** and **Accept only SSL Requests**.

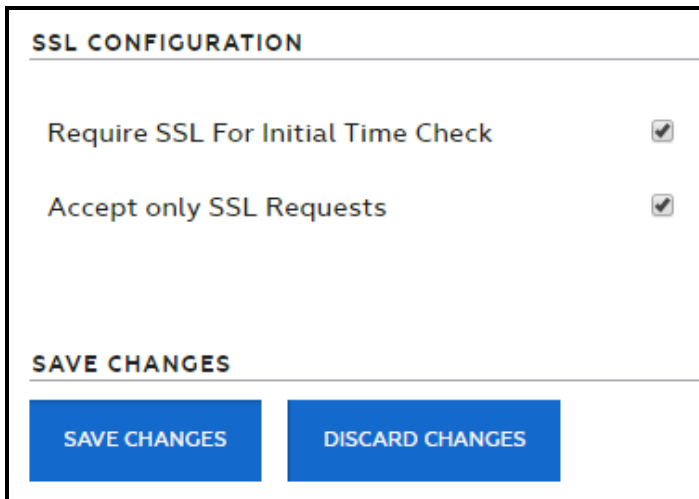

The screenshot displays the 'SSL CONFIGURATION' settings page. It features two checkboxes, both of which are checked: 'Require SSL For Initial Time Check' and 'Accept only SSL Requests'. At the bottom of the configuration area, there are two blue buttons: 'SAVE CHANGES' and 'DISCARD CHANGES'.

3. Select **Save Changes**.
4. Reboot and register (if not done yet) the dock.

#### The dock UI shows something other than a red X next to Time Server

---

The IP addresses of Axon Evidence (Evidence.com) need to be white-listed. Contact customer service to obtain a list of these IPs.

## HTTPS shows a red "X" or "NA"

SYSTEM STATUS	
	NULL – NULL 1/25/2017 – 10:17:59 NULL
NETWORKING	
✓ IP Address ( dynamic )	
✓ Internet Gateway	
✓ DNS Server	
✓ Time Server	
✗ HTTPS (Port 443)	NA
✗ Evidence.com Registration	Not registered
MAC Address	
Serial #	
Firmware	null

1. Outbound traffic on port 443 (SSL) appears to be blocked on the agency firewall. Work with your agency IT department to ensure this port is opened outbound.
2. The IP addresses of Axon Evidence (Evidence.com) need to be allowlisted. Contact customer service to obtain a list of these IPs.

## No IP address found or all fields red

SYSTEM STATUS	
	NULL – NULL 1/25/2017 – 10:17:59 NULL
NETWORKING	
✗ IP Address ( NA )	NA
✗ Internet Gateway	NA
✗ DNS Server	NA
✗ Time Server	NA
✗ HTTPS (Port 443)	NA
✗ Evidence.com Registration	NA
MAC Address	
Serial #	
Firmware	null

1. Ensure the dock status light is a solid green. Red X's will appear if the dock has not fully booted up (the boot-up process takes roughly one minute).
2. Ensure physical connectivity (ethernet cable) to the WAN port on the dock.
3. Ensure the dock is plugged into a valid internet source/active port.

4. If your agency uses statically-assigned IP addresses:
  - a. Assign a static IP address on the networking tab on the Axon Dock UI. You may need to contact your agency IT department for this information.
  - b. If errors persist, double-check the static entries against another computer on your network and ensure you entered two valid DNS addresses.

## What do the dock registration error codes mean?

Error	Explanation
100010	Invalid credentials: either a password or username has been entered incorrectly or the domain name for those login credentials is incorrect.
100003	A network related issue occurred. If a static IP address has been assigned to this dock, ensure all entries are correct and that two DNS entries have been added.
100005	There have been too many failed registration attempts. Click the Reset Registration button at the bottom left and after the reset has completed, try again.
100008-1	A network-related issue occurred. Reset the dock by pressing the reset button by the WAN port with a paperclip or similar tool. If that doesn't work, unplug the power for 30 seconds, then reconnect and let the dock reboot (this takes 1–2 minutes). Try registering again.
Host Not Found / 100003	No internet connection or the Evidence.com sub-domain name is misspelled. Other possibilities include bad internet port, bad ethernet cable, or an incorrectly entered static IP entry.
1060	"****.evidence.com is not a valid hostname". The sub-domain name is misspelled.
Error: 1	The domain name field is empty.
100006	SSL handshake failed.Ensure your sub-domain name and Evidence.com credentials are correct.
10020	Access denied. You do not have permission to view this object. The person attempting to register this dock is not in the default Admin role or their role does not have the Device Administration permission enabled.

## Camera are flashing red, yellow, and green repeatedly

Several conditions that can cause cameras to flash this sequence. It typically indicates the dock is experiencing a network error or has not yet been registered to your agency's Axon Evidence account.

Also, an Axon Dock firmware update will cause the cameras in the docking station to flash like this for 5–10 minutes. If the dock does not resume normal operation after that, follow the steps below.

Ensure your Axon Dock has been [registered](#) (see page 4). If it's already registered and was working properly, keep reading.

## Re-seat the camera

Remove and re-seat the camera/controller and wait two minutes to see if the condition corrects itself.

## Reset your dock

Using a paperclip or similar item, press the reset button on the dock.

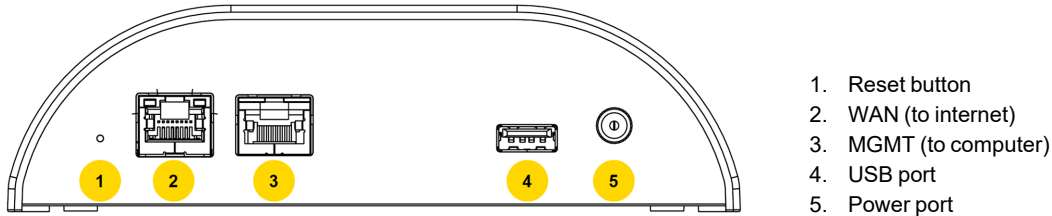

The dock begins a reboot process that takes 1–2 minutes. If this reset doesn't work, continue below.

## Repower your dock

Pull the power cable from the dock, wait one minute, and reconnect. The dock begins a reboot process that takes 1–2 minutes. If this reset doesn't work, continue below.

## Check network configuration

Check with your IT department to ensure no changes have been made to your firewall or other security devices. Specifically, for the following three ports:

- Port 443 (TCP) is open for traffic to your agency's domain ([youragency].evidence.com). This port is used by the dock to send video and data files to Axon Evidence using the HTTPS protocol.
- Port 53 (UDP) is open for access to DNS, if your network uses external (internet) DNS servers. When using external DNS servers this port is necessary for the dock to locate the servers for your Axon Evidence account.
- Port 80 (TCP) for time synchronization.

If you are not sure or IT can't confirm if these ports are opened or closed, connect a laptop to the dock via the MGMT (LAN) port (see image above) and access the dock status page by visiting 10.10.1.1 in a browser. The dock will attempt to clarify which port it believes to be blocked.

Not enabling inbound and outbound traffic on the above ports will disable the dock's ability to upload.

## Check allowlisting

Confirm that the Axon Evidence IP addresses are allowlisted. Not allowlisting all Axon Evidence IP addresses may affect your uploads. If you need a list of Axon Evidence IPs, [contact us](#).

## Check static IP addresses

If your agency is using static IP addresses on your dock, confirm that no changes have been made to those IP address ranges. If changes have been made, the static IP addresses assigned to the dock may no longer be usable and must be updated by your IT department.

## Check IP restrictions

If using IP restrictions, ensure the IP addresses assigned to the dock falls within the range of your accepted IP addresses. If the dock's IP address is outside the range, evidence will not upload.

## Ensure ethernet ports are active

Confirm that the ethernet wall ports or switch (if in use) are still active. Some IT departments will not activate ethernet ports until ready to use. This can cause others to be inadvertently turned off and disable internet access.

Switches, which often look like a typical router, are powered separately from your dock. Ensure the switch is powered on and showing internet traffic (usually blinking lights).

## None of the above worked

If your IT department confirmed that no changes were made and all necessary firewall ports and IP addresses are correct, check for potential camera issues:

1. If all the cameras/controllers in the Axon Dock are blinking red, yellow, and green, there is likely a network or service issue. Check with your agency IT for any network connectivity issues. If your network is functioning correctly, sign into the dock, go to the Status page, and check the device status. Also, check for any Axon service updates or announcements. If there are no errors, [contact us](#) for further assistance.
2. If the camera/controller continues to blink red, yellow, and green, place a camera/controller that is operating normally in the dock and wait two minutes.
  - a. If the normal operating device blinks red, yellow, and green, there is a network or service issue. See #1 above.
  - b. If the normal operating device is not blinking red, yellow, and green after two minutes, reconnect the original device, sign into the dock, go to the Status page, and check the device status. If there are no errors, [contact us](#) for further assistance.

## Unable to reach the Axon Dock status page

---

If the computer connected to the dock can't connect to the status page after entering in 10.10.1.1 in a browser, ensure:

- The dock has power
- The computer is connected to the MGMT (LAN) port, not the WAN port of the dock (see image above)
- Wi-Fi on the computer is disabled or turned off
- The computer is not set to a static IP; if set to a static IP, the computer must be temporarily set to DHCP to reach the dock status page.

## Technical information

### Technical support

---

Visit [www.axon.com](http://www.axon.com) and view the support options or call 1-800-978-2737.

### Warranty

---

Axon Enterprise, Inc. warranty provisions are applicable on all Axon Body products. See [www.axon.com](http://www.axon.com) for detailed warranty information.

### Compliance marks

---

Find compliance marks for Axon Docks in the **Technical information** section of the corresponding body camera user guide.